



TECHNICAL BULLETIN

Audco

TIPV-Twin Isolation Plug Valve
Double Block & Bleed Plug Valve

FCD AUEETB0005-02 06/13



Contents

Introduction	2
Design Features	3-7
Typical Installations	8-9
Figure Numbering / Standards	10
Pressure Testing	11
Materials	12
Engineered Solutions	13
Valve Data	14-19
Sealants	20-21
Sealants Injection Equipment	22
Products of Success	23

Introduction - TIPV **Twin Isolation Plug Valve**

Based on Audco Super-H pressure balanced taper plug technology, Twin Isolation Plug Valve offers true bubble tight double block and bleed, within a single valve body.

The oil and gas industry is no longer satisfied with the shut-off provided by conventional double block and bleed ball, gate or plug valves. True double block has become a prime requirement as safety standards are raised throughout the industry, especially where it is necessary for an operator to work downstream (or upstream) of the valve.

A further advantage of true double isolation (where the first plug gives complete isolation), is that the bleed point can be used to verify that no contamination has occurred when more than one type of line medium has passed down the pipeline.

The Audco Super-H plug valve is widely acknowledged in the oil and gas industry for its superior shut-off at high differential pressures together with excellent reliability and durability. This same design is used in the Audco Twin Isolation Plug Valve.

TIPV Design Features

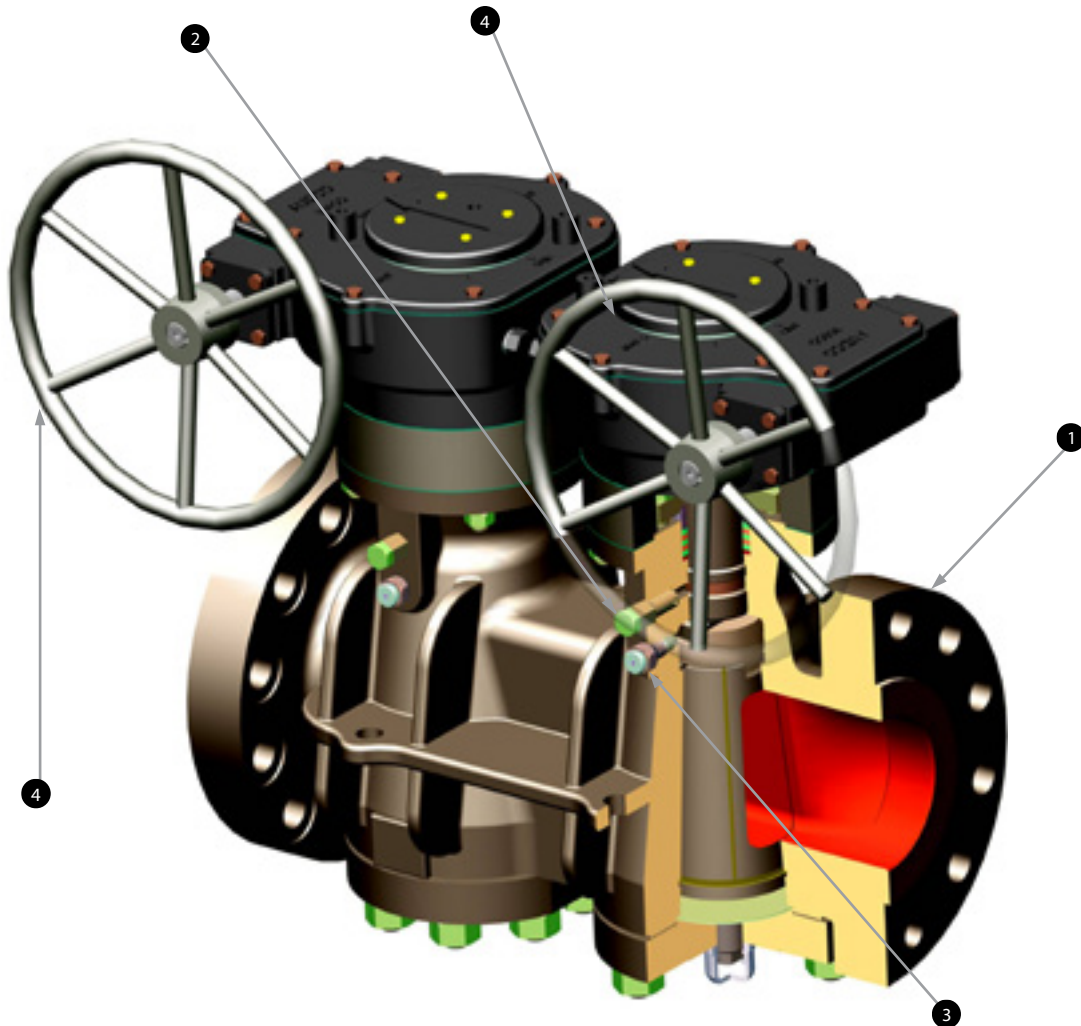

- ① Same face-to-face as one valve.
- ② In-line emergency stem sealing.
- ③ In-line sealant injection point.
- ④ Choice of mounting positions for actuators and handwheels.
- ⑤ Bleed port.
- ⑥ Bleed valve flange interface.

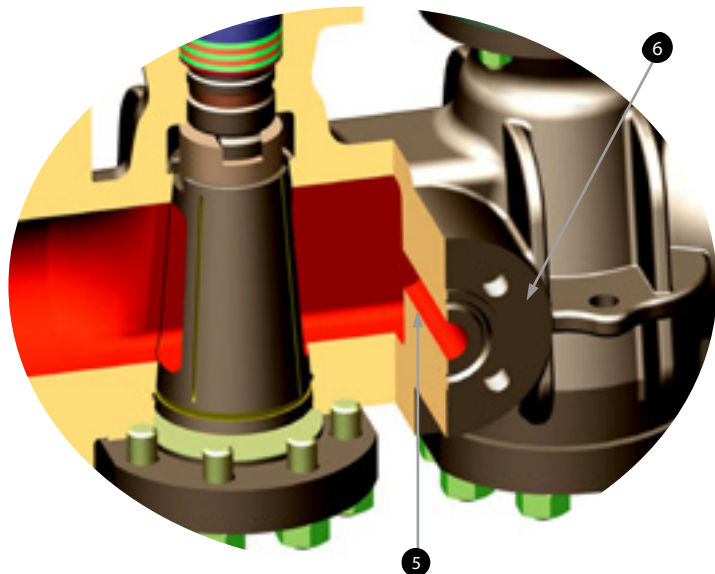

What are the benefits?

- No pipework modification - total interchangeability with existing valves.
- Choice of bleed connection options.
- Same range as single valve including hard facing.
- Meets the same industry and fire-test standards as a single valve.
- Low life cycle cost - less than two single valves.
- Assured sealing on both sides of the valve.
- Reduced leak paths - eliminates inter-valve pipework on double block and bleed configurations.
- Compact, lightweight alternative to gate valves and ball valves in series.

Single Plug - Single Isolation

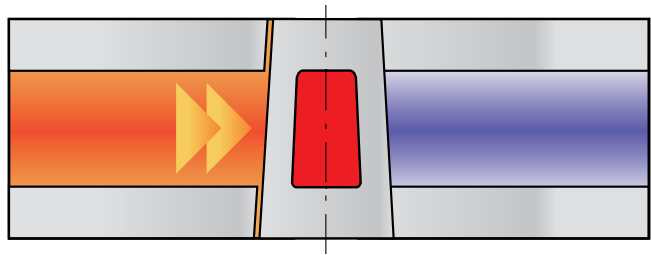

Twin Plug - Twin Isolation

Independently operated plugs mean maximum downstream isolation safety.

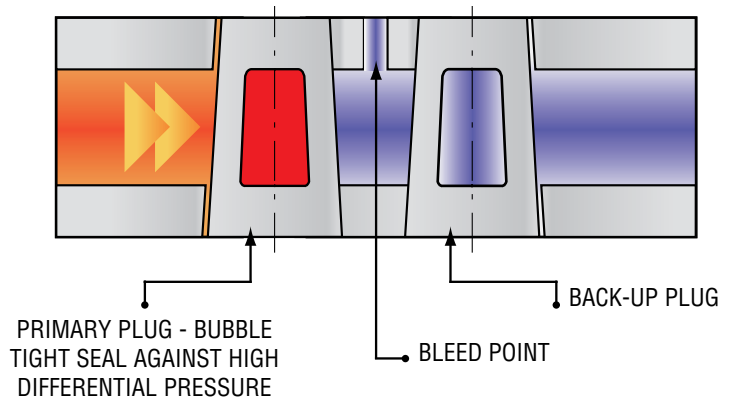

Range

inches	mm	Class					
		150	300	600	900	1500	2500
3/4	20	●	●	●	●	●	●
1	25	●	●	●	●	●	●
1 1/2	40	●	●	●	●	●	●
2	50	●	●	●	●	●	●
3	80	●	●	●	●	●	●
4	100	●	●	●	●	●	●
6	150	●	●	●	●	●	●
8	200	●	●	●	●	●	●
10	250	●	●	●	●	●	●
12	300	●	●	●	●	●	●
14	350	●	●	●	●	●	●
16	400	●	●	●	●	●	●
18	450	●	●	●	●	●	●
20	500	●	●	●	●	●	●
24	600	●	●	●	●	●	●

Why Select a Plug Valve?

Robust **metal-to-metal seats** cope well with the solid impurities that can run at high velocities in close proximity to the integral seating surfaces, particularly when the valve is opened against a high differential pressure. (Fig. 5)



Fig.5

Robust metal-to-metal seats have also high resistance to solids objects and **lack of gap/cavity** between plug and body ensure that particles do not become trapped between plug and body thus avoiding damage to the seats while closing the valve. (Fig. 6)



Fig.6

Large seating area further enhances the TIPV resistance to erosion. The wide area maximizes the effectiveness of sealant, so that if the valve starts passing it can quickly be solved by injecting Audco Sealant, restoring the valve's **bubble tight shut-off** capabilities without the need of valve overhaul. Sealant can be injected with the valve in any position and also under pressure, making the valve **in-line maintainable**. (Fig. 7)



Fig.7

When the valve is open, unlike in other valve designs, the **seats are well protected** from the line media. This ensures that even if the valve is left open for long periods of time, its seating areas will not get damaged, thus ensuring good sealing and **long valve life**. (Fig. 8)



Fig.8

Proven plug valve integrity - setting new standards for double block & bleed

True twin isolation within a single valve body

	<p>Compared with Gate Valves</p> <ul style="list-style-type: none"> • Same face-to-face but smaller overall • Compact design means less weight
--	---

	<p>Compared with Ball Valves</p> <ul style="list-style-type: none"> • One TIPV replaces two ball valves • Less interconnecting pipework means fewer leak paths • Weight saving • Cost saving
--	--

Main Features

Principles of Operation

Audco Twin Isolation Plug Valves feature two separate Protected Pressure Balanced Taper Plugs and a centrally located bleed port, integral with the body. They are designed to give bubble tight shut off on both high and low pressure applications. This is a robust, In-Line Maintainable valve with low maintenance requirements. The valve body is a rigid single piece casting. The blow out proof valve stems are fugitive emissions tested. The separate plugs are retained in the body by separate bolted covers. The design incorporates provision for external maintenance of the individual stem packings.

Plug Balancing

All TIPV valves are protected against the possibility of seizure due to taper locking. Taper locking is caused by an imbalance of forces acting on the plug due to line pressure finding its way into the large end of the plug chamber. As shown by the arrows in Fig. 1, the resultant force tends to push the plug upwards, jamming it in its tapered bore. The plug can remain locked even when line pressure is subsequently reduced.

In an attempt to combat taper locking, conventional valves utilise the pressure of the plug sealant, acting on the upper face of the plug, to react against the upwards force. This reduces, but does not eliminate, the possibility of taper locking - and requires regular sealant injection to maintain valve freedom.

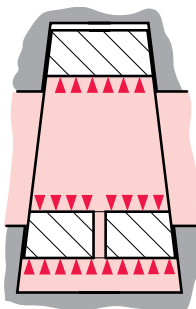

Fig.1

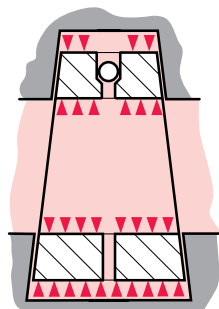

Fig.2

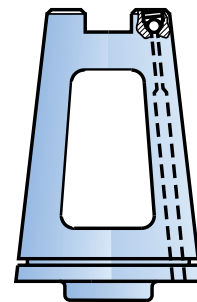

Fig.3

Pressure Balancing

Pressure balanced plug valves incorporate pressure balanced plugs, as shown in Fig. 2. The drilling and check valve in the top section of the plug allow the line pressure itself to counteract the upwards force, preventing any possibility of taper locking - without the need for frequent sealant injection.

Protected Pressure Balancing (P)

Flowserve Patent

For increased reliability in service and where there is a possibility of particles in the media we incorporate Protected Pressure Balance as standard on the TIPV (Fig 3). This design ensures that the balancing holes are not exposed to the line media in the plug port, providing added security compared with normal pressure balancing.

Super-LoMu Treatment

Super LoMu is our proprietary PTFE based anti-friction treatment. All TIPV plugs and stems are Super LoMu treated to ensure our valves have the lowest possible torques over the longest possible lifetime. Super LoMu is a treatment of the metal surface that reduces coefficient of friction while maintaining a true metal-to-metal contact, and we can apply it to every material combination.

Emission Control

Industry standards are tightening the requirements on emissions levels permitted from pressurized equipment. TIPV valves are ahead of the game -and are designed and tested to meet the most stringent fugitive emission requirements. Our adjustable gland design, combined with high performance graphite stem packing materials, ensures low emissions over extensive temperature and mechanical cycling, even without the use of O-rings or PTFE seals.

Typical Installations

Gas Transportation - Gas Compression Station

Configuration using ball valves

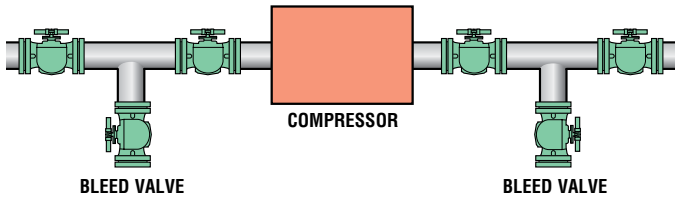

Configuration using twin isolation plug valves

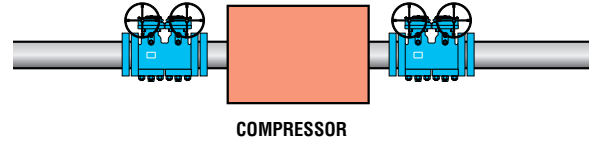

Oil & Gas Production - Well Heads Manifold

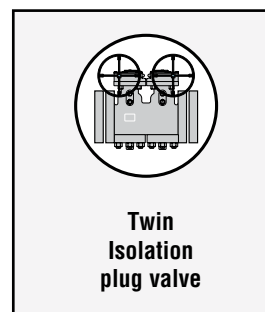
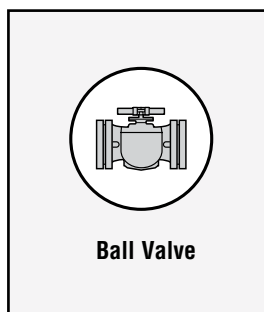
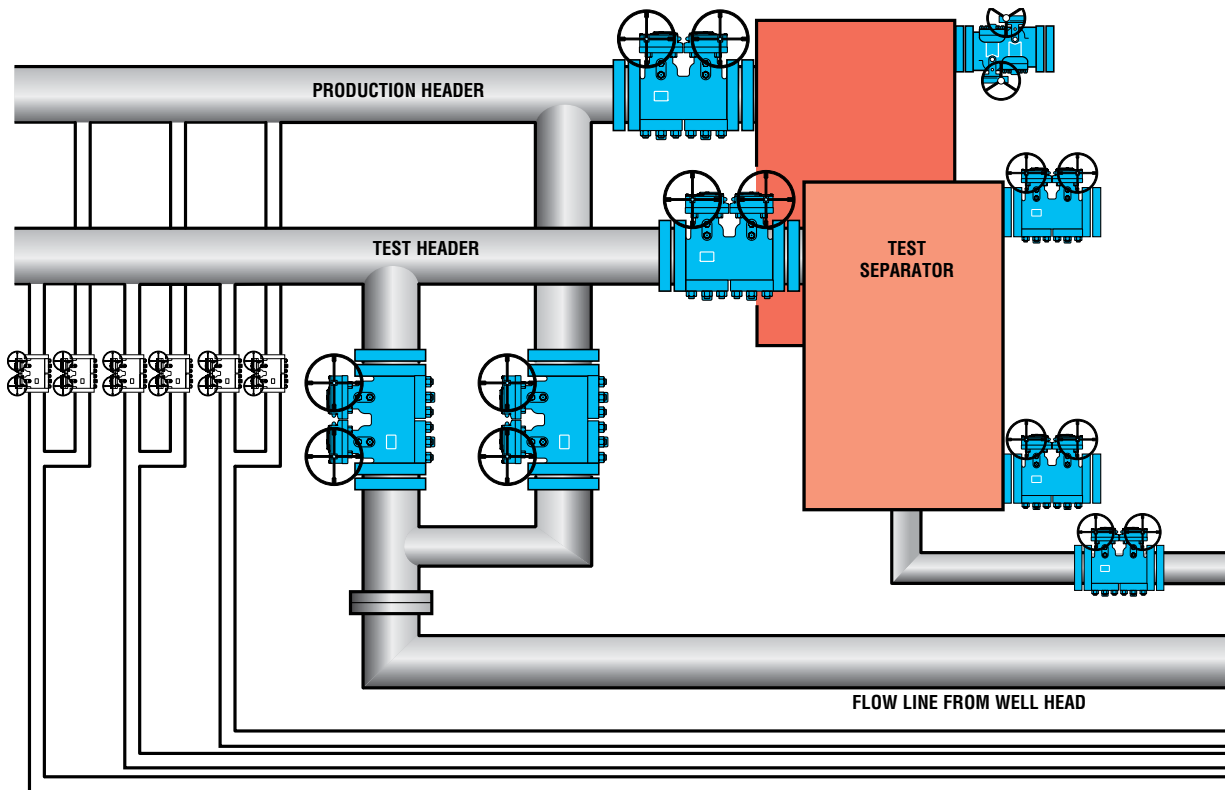



The valves illustrated are 6" class 2500 with hub ends, in carbon steel, manually operated.
criteria for selection: bubble tight isolation and compact design.



The valves illustrated are 12" class 2500 with hub ends. Criteria for selection:
tight shut off, safety reliability and low maintenance.

Figure Numbering

A familiarity with our figure numbering system is not necessary when specifying or ordering our valves. Providing a full description of the valve is given, our sales office will translate this into a figure number. A full description of the valve begins with 'TIPV Pressure Balanced Valve', and gives size, pressure rating, flanging details, materials of construction, application and every customer datasheet or specification available.

We give an example below with the most common coding in order to illustrate a typical figure number:

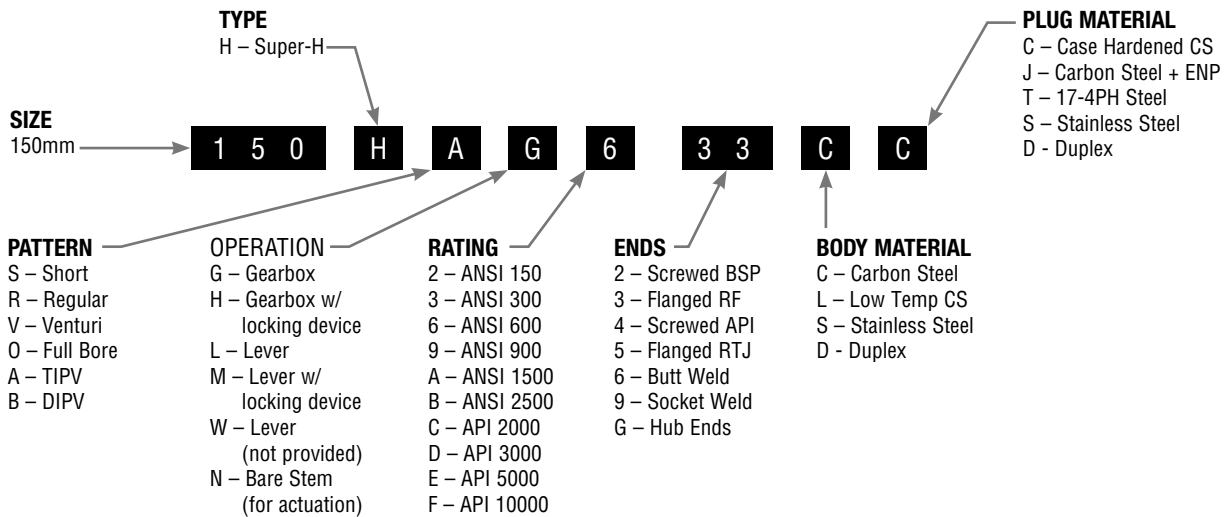

Standards and Quality Assurance

TIPV valves meet the requirements of API 6D, API 599, BS5353 and ANSI B16.34 as standard. Valves to meet API 6A are also available. Typical industry standards that we are often asked to comply with are listed in the below table. Other standards can be considered against specific request.

API 6D (ISO 14313)	Specification for pipeline valves
API 6A (ISO 10423)	Specification for wellhead equipment
API 599	Metal plug valves – flanged, threaded and welding ends
BS 5353	Specification for steel plug valves
ASME B16.34	Valves – flanged, threaded and welding ends
BS EN14141	Valves for natural gas transportation in pipelines. Performance requirements and tests
ISO 15848-1/2	Industrial valves. Measurement, test and qualification procedures for fugitive emissions
ASME B16.10	Face-to-face and end-to-end dimensions of valves
BS EN 12627 BS EN 558 (formerly BS 2080)	Face-to-face, center-to-face, end-to-end, and center-to-end dimensions of flanged and butt welding end steel valves for the petroleum, petrochemical and allied industries
ASME B16.5	Pipe flanges and flanged fittings
BS EN 12266-1 BS EN 12266-2 API 598	Industrial valves. Testing of valves. Pressure tests, test procedures and acceptance criteria.
ISO 10497	Testing of valves. Fire type-testing requirements
API 6FA	Specification for fire test for valves
BS EN ISO 15156 (formerly NACE MR0175)	Sulphide stress cracking resistant metallic material for oilfield equipment
BS EN ISO 9001	Quality assurance approval standard
97/23/EC	Pressure equipment directive

Pressure Testing

All TIPV valves are hydrostatically tested on body and all 4 seats (2 seats per plug) at the following pressures before dispatch:

Valve Rating	Maximum C.W.P.		Body Test		Seat Test	
	Bar	Psi	Bar	Psi	Bar	Psi
PN20 - ANSI 150	19.5	285	29.3	427.5	21.5	313.5
PN50 - ANSI 300	51.1	740	76.7	1110	56.3	814
PN100 - ANSI 600	102.1	1480	153.2	2220	112.4	1628
ANSI 800	138	2000	207	3000	151.8	2200
PN150 - ANSI 900	153.2	2220	229.8	3330	168.6	2442
PN250 - ANSI 1500	255.3	3705	383	5558	280.9	4075.5
PN420 - ANSI 2500	425.5	6170	638.3	9255	468.1	6787
API 2000	138	2000	276	4000	138	2000
API 3000	207	3000	414	6000	207	3000
API 5000	345	5000	517	7500	345	5000
API 10000	690	10000	1035	15000	690	10000

(Class 800 pressures are taken from BS 5353, API pressures are taken from API 6A, all other pressures are taken from ANSI 16.34. The test pressures from ASME B16.34 are those relevant to Carbon Steel ASTM A216 Gr.WCB)

Even though API6D generally allows a seat leakage rate while testing metal seated valves, it shall be noted that for lubricated plug valves (such as the TIPV) in accordance with API6D no seat leakage is allowed (ISO 5208 class A).

Each relevant standard defines the minimum length of time for which each test pressure is to be maintained and also the testing operations sequence. TIPV valves are tested as a minimum to API 6D, whose test durations are longer than API 598 and BS EN 12266-1

Valve Size		API 6D	
Mm	In	Shell Test (min)	Seat Test (min)
≤ 50	≤ 2	2	2
65 – 100	2 ½ - 4	2	2
150	6	5	5
200 – 250	8 – 80	5	5
300	12	15	5
350 – 450	14 – 18	15	5
≥ 500	≥ 20	30	5

Other test durations can be accommodated to satisfy a particular order specification, optional special tests are also available such as

- Low pressure air test
- High pressure gas test
- Fugitive emission testing
- Low and high temperature testing

Materials

Audco Valves has extensive experience in manufacturing our TIPV in a wide range of materials to comply with any particular application or project specification. Below are few samples of the most common material combinations:

Service	Body / Cover	Plug	Stem / Eq Ring	Cover Bolting
Sweet Natural Gas and most non-aggressive services	Carbon Steel ASTM A216 WCB/WCC	ASTM A216WCB/WCC + Case Hardening	Alloy Steel ASTM A322 4140	ASTM A193 B7 + ASTM A194 2H (B7M/2HM if NACE bolting is required)
Sour Services (ISO 15156 – NACE)		ASTM A216WCB/WCC + ENP		
Abrasive Services		17-4PH Martensitic Stainless Steel ASTM A747 Gr. Cb7Cu1	17-4PH Martensitic Stainless Steel ASTM A564 Ty 630	
API 6A	60K Carbon Steel ASTM A487 Gr 4			
Low Temperature Services	Low Temp. Carbon Steel ASTM A352 LCB/LCC	ASTM A352 LCB/LCC + ENP	ASTM A322 4140	ASTM 320 L7 + ASTM A194 7
Corrosive Services	Austenitic Stainless Steel ASTM A351 CF3M/CF8M	ASTM A351 CF3M/CF8M + ENP	ASTM A564 Ty 630	ASTM A193 B8M + ASTM A194 8M
Corrosive and Abrasive Services	Duplex / Super Duplex Stainless Steel ASTM A995 4A/5A	ASTM A995 4A/5A + ENP	ASTM A182 F51/F55	UNS S32760
Highly Corrosive Services	ASTM A216 WCB/WCC + Inconel 625 Overlay	ASTM A216 WCB/WCC + Inconel 625 Overlay + ENP	Inconel 718	ASTM A193 B7 + ASTM A194 2H
Highly Abrasive Services	ASTM A216 WCB/WCC + Stellite Hard Facing	ASTM A216 WCB/WCC + Stellite Hard Facing	ASTM A322 4140	

Notes: Other Material combinations are available

Super LoMu Anti Friction Treatment (AFT) is always applied on plugs and stem to reduce friction

For small or flat parts, equivalent forged or plate grade is also widely used in lieu of castings

TIPV for Special Abrasive and Corrosive Services

TIPV plug valves are ideally suited to applications where the line media is abrasive or corrosive, even with standard materials.

For very aggressive services, the internal surfaces of the valves can be hard faced or overlaid with a selection of alloys specially identified and tested by Audco Valves. The choice of materials and surface treatments depends on the nature of the service. Hard facing and overlay can be applied to internal parts in four levels of increasing coverage:

- On the seating surfaces of plug and body only
- On all the surfaces of the body and plug tapers
- On all the surfaces of the body and plug tapers plus the body and plug flow bore
- On all wetted parts

The result is superior technical performance and dramatically extended valve life at an affordable cost.

We recommend that customers consider hard facing or overlay for severe applications, such as: sand entrained oil and gas production, water injection, high temperature catalyst conveying, slurry handling and transportation etc.

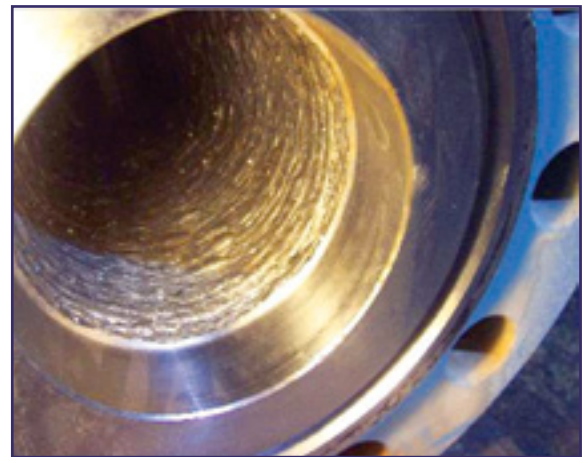

Engineered Solutions

At Audco Valves, we specialize in meeting customer specifications and find solutions for your particular installation requirements. We can install any type of actuator and in every orientation, and address any other special need.



Installation of 2 pneumatic actuators



Different orientation of input shafts for electric actuator to customer requirements



Bleed valve to fit customer specifications



Extended stems for customer accessibility requirements



Customer agreed intermediate pressure classes, in this case 8000psi



Interlock systems for valve manifolds

TIPV - Class 150

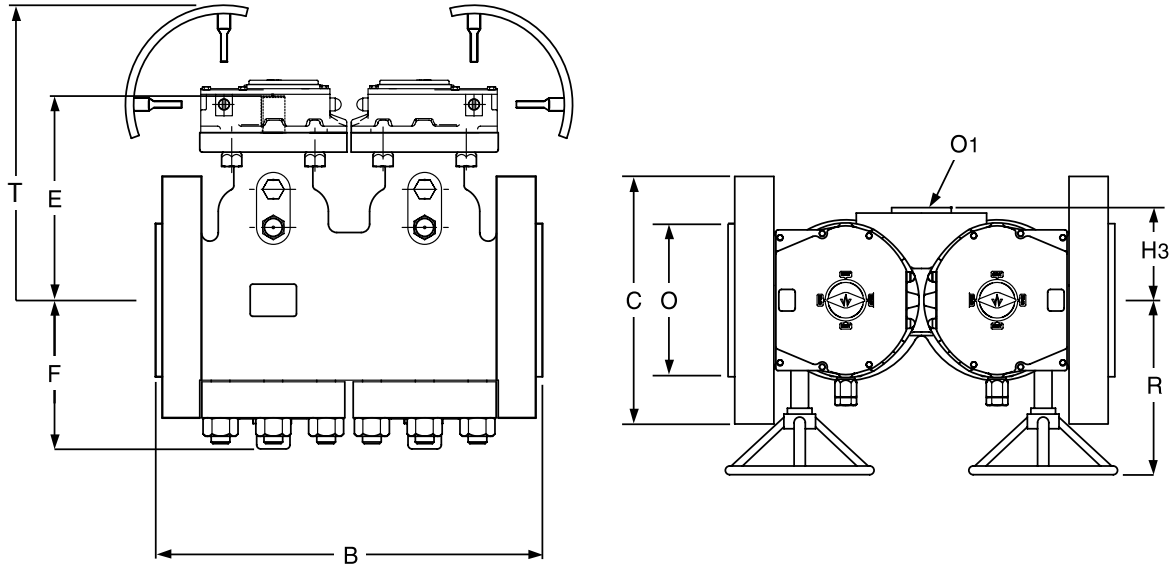

			50	80	100	150	200	250	300	350	400	450	500	600
B	Face-to-face RF	mm	292	356	432	559	660	788	838	889	991	1092	1194	1397
C	Flange Diameter	mm	152	191	229	279	343	407	483	534	597	635	699	813
	Flange Thickness (incl RF ht)	mm	31.8	38.2	44.5	54.0	62.0	70.0	73.0	76.3	82.6	89.0	95.3	108.0
	Handwheel Diameter	mm	200*	250*	250	400	400	400	400	400	400	500	500	600
E	CL to top of Stem	mm	213	250	250	300	349	380	437	470	523	549	630	760
F	CL to bottom of Body Cap	mm	125	150	179	210	273	308	340	384	415	455	570	570
O	RF Diameter	mm	92	127	157	216	270	324	381	413	470	533	584	692
T	CL to top of Handwheel	mm	306*	360*	360	500	525	555	650	680	675	750	820	975
R	CL to face of Handwheel	mm	221*	265	265	321	391	391	408	450	429	500	500	550
O1	Bleed Size	mm	1/2" CL.150	1/2" CL.150	1/2" CL.150	1" CL.150	1" CL.150	1" CL.150	1" CL.150	1" CL.150	1" CL.150	1" CL.150	1" CL.150	1" CL.150
H3	CL to end of Bleed Flange Face	mm	80	95	95	144	170	180	200	240	247	222	370	413
	Operating Torque	Nm	116	195	290	550	875	1151	1550	1950	2300	2900	3500	5100
	Weight (Approx)	mm	52	111	136	219	388	563	762	1113	1400	1866	2333	3417

* If valve operated by gear or manual handwheel

Notes:

Dimensions in these tables are for standard valves and are subject to change. For layout purposes please request a drawing.

Torques displayed are for standard materials of construction at the plug stem, check with Audco Valves if you need to carry out any actuator sizing

Weights are approximate and for bare stem valve

To maintain a compact face to face dimension, some size/pressure class combinations may contain tapped holes in flange connections. If tapped holes are not acceptable please contact Audco, we can provide a suitable solution.

TIPV - Class 300

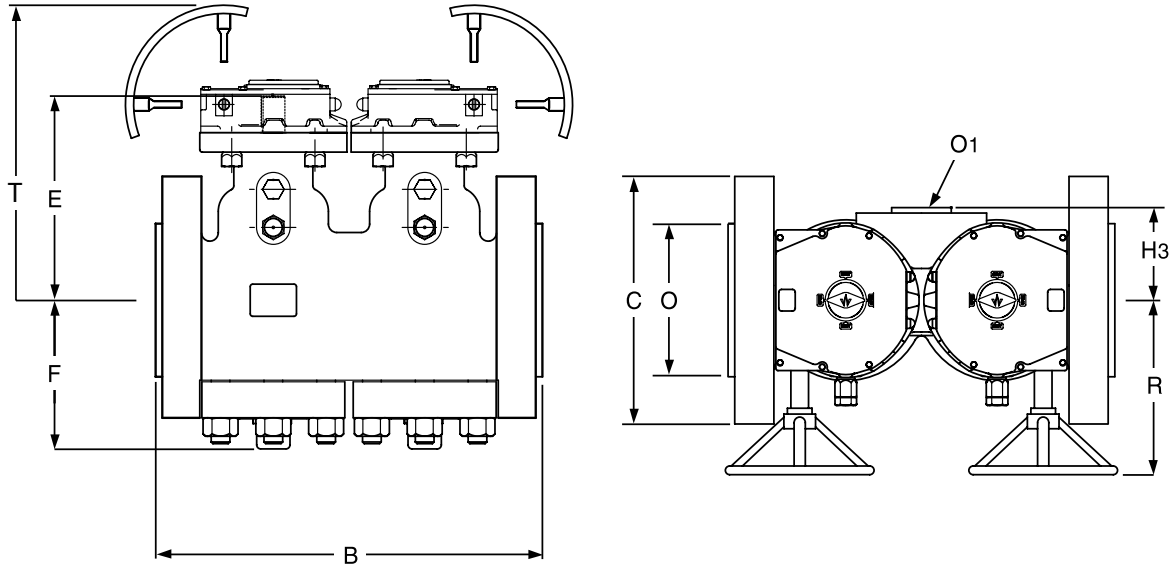

		50	80	100	150	200	250	300	350	400	450	500	600	
B	Face-to-face RF	mm	292	356	432	559	660	788	838	889	991	1092	1194	1397
C	Flange Diameter	mm	165	219	254	318	381	445	521	584	648	712	775	914
	Flange Thickness (incl RF ht)	mm	31.8	38.2	44.5	54.0	62	70	73	76.3	82.6	89	95.3	108
	Handwheel Diameter	mm	200*	250*	250	400	400	400	400	400	400	500	500	600
E	CL to top of Stem	mm	213	250	250	300	349	380	437	470	523	549	630	760
F	CL to bottom of Body Cap	mm	125	150	179	210	273	308	340	384	415	455	570	570
O	RF Diameter	mm	92	127	157	216	270	324	381	413	470	533	584	692
T	CL to top of Handwheel	mm	306*	360*	360	500	525	555	650	680	675	750	820	975
R	CL to face of Handwheel	mm	221*	265*	265	321	391	391	408	450	429	500	500	550
O1	Bleed Size	mm	1/2" CL.300	1/2" CL.300	1/2" CL.300	3/4" CL.300	3/4" CL.300	3/4" CL.300	3/4" CL.300	3/4" CL.300	1" CL.300	1" CL.300	1" CL.300	1" CL.300
H3	CL to end of Bleed Flange Face	mm	80	95	95	144	170	180	200	240	247	222	370	413
	Operating Torque	Nm	140	241	360	700	1100	1400	2000	2200	2900	3650	4400	6200
	Weight (Approx)	mm	52	111	136	219	388	563	762	1113	1400	1866	2333	3417

* If valve operated by gear or manual handwheel

Notes:

Dimensions in these tables are for standard valves and are subject to change. For layout purposes please request a drawing.

Torques displayed are for standard materials of construction at the plug stem, check with Audco Valves if you need to carry out any actuator sizing

Weights are approximate and for bare stem valve

To maintain a compact face to face dimension, some size/pressure class combinations may contain tapped holes in flange connections. If tapped holes are not acceptable please contact Audco, we can provide a suitable solution.

TIPV - Class 600

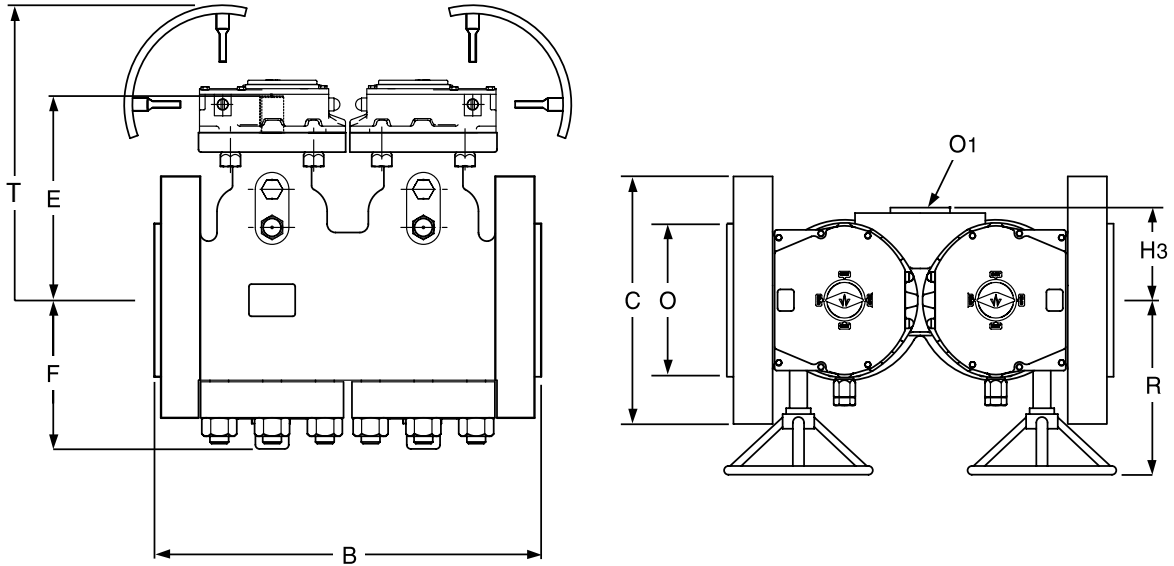

			50	80	100	150	200	250	300	350	400	450	500	600
B	Face-to-face RF	mm	292	356	432	559	660	788	838	889	991	1092	1194	1397
	Face-to face RTJ	mm	295	359	435	562	663	791	841	892	994	1095	1200	1407
C	Flange Diameter	mm	165	210	273	356	419	508	559	604	686	743	813	940
	Flange Thickness RF (incl RF ht)	mm	31.8	38.2	44.5	54	62	70	73	76.3	82.6	89	95.3	108
	Flange Thickness RTJ (incl RTJ ht)	mm	33.3	39.7	46.0	55.5	63.5	71.5	74.5	77.8	84.0	90.5	98.4	112.7
	Handwheel Diameter	mm	200*	250*	250	400	500	500	400	500	500	500	500	600
E	CL to top of Stem	mm	213	250	278	354	415	445	505	530	585	615	700	840
F	CL to bottom of Body Cap	mm	125	150	179	210	273	308	340	384	415	455	570	570
O	RF Diameter	mm	92	127	157	216	270	324	381	413	470	533	584	692
	RTJ Diameter	mm	108	146	175	241	302	356	413	457	508	575	635	749
T	CL to top of Handwheel	mm	306*	360*	389	542	600	684	720	745	794	818	890	1050
R	CL to face of Handwheel	mm	221*	265*	265	390	390	475	495	450	480	500	500	550
O1	Bleed Size	mm	1/2" CL.600	1/2" CL.600	1/2" CL.600	3/4" CL.600	3/4" CL.600	3/4" CL.600	3/4" CL.600	3/4" CL.600	1" CL.600	1" CL.600	1" CL.600	1" CL.600
H3	CL to end of Bleed Flange Face	mm	80	95	95	144	170	180	200	240	247	222	370	413
	Operating Torque	Nm	225	385	581	1100	1725	2225	3130	3903	4650	6000	7500	10268
	Weight (Approx)	Kg	52	111	136	219	388	563	762	1113	1400	1866	2333	3417

* If valve operated by gear or manual handwheel

Notes:

Dimensions in these tables are for standard valves and are subject to change. For layout purposes please request a drawing.

Torques displayed are for standard materials of construction at the plug stem, check with Audco Valves if you need to carry out any actuator sizing

Weights are approximate and for bare stem valve

To maintain a compact face to face dimension, some size/pressure class combinations may contain tapped holes in flange connections. If tapped holes are not acceptable please contact Audco, we can provide a suitable solution.

TIPV - Class 900

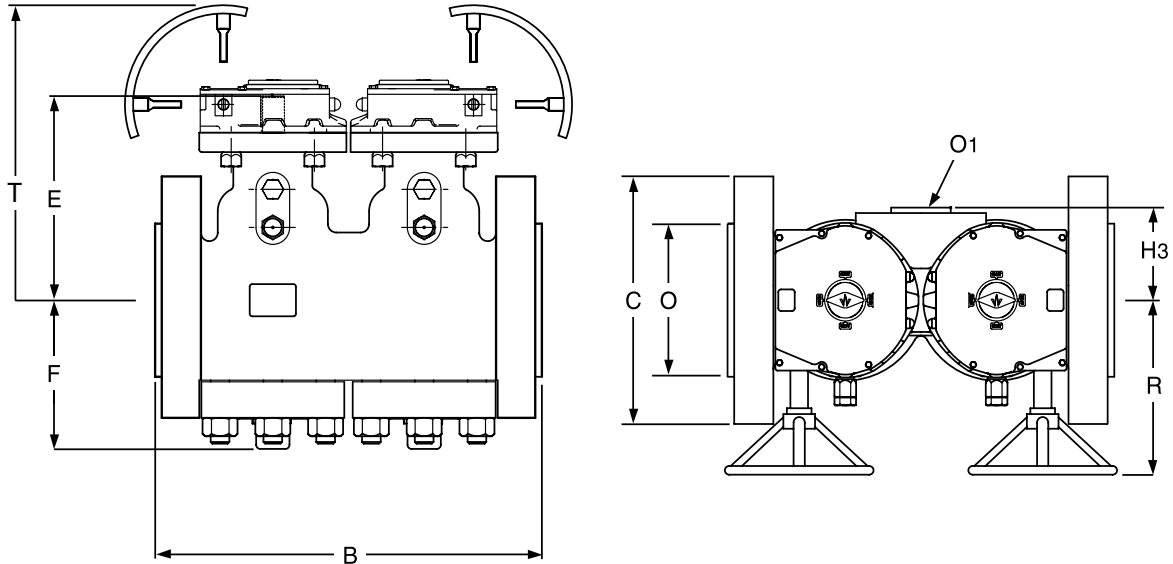

			50	80	100	150	200	250	300	350	400	450	500	600
B	Face-to-face RF	mm	369	381	457	610	737	838	965	1029	1130	1219	1321	1549
	Face-to face RTJ	mm	372	384	460	613	740	841	968	1039	1140	1232	1334	1568
C	Flange Diameter	mm	216	242	293	381	470	546	610	642	705	787	857	1042
	Flange Thickness RF (incl RF ht)	mm	44.5	44.5	51.0	62.0	70.0	76.2	85.8	92.2	95.3	108.0	114.4	146.0
	Flange Thickness RTJ (incl RTJ ht)	mm	46.0	46.0	52.5	63.5	71.5	77.7	87.3	96.8	100.0	114.3	120.7	155.6
	Handwheel Diameter	mm	300	300	300	400	400	500	500	500	500	400	500	500
E	CL to top of Stem	mm	225	285	335	395	425	533	531	542	554	635	638	763
F	CL to bottom of Body Cap	mm	146	160	181	235	285	355	387	407	484	484	540	611
O	RF Diameter	mm	92	127	157	216	270	324	381	413	470	533	584	692
	RTJ Diameter	mm	124	155	181	241	419	362	419	467	524	594	648	772
T	CL to top of Handwheel	mm	365	424	453	560	590	708	743	776	724	830	830	993
R	CL to face of Handwheel	mm	272	299	397	325	429	450	486	480	528	543	543	563
O1	Bleed Size	mm	1/2"	1/2"	1/2"	3/4"	3/4"	3/4"	1"	1"	1"	1"	1"	1"
		CL.900	CL.900	CL.900	CL.900	CL.900	CL.900	CL.900	CL.900	CL.900	CL.900	CL.900	CL.900	CL.900
H3	CL to end of Bleed Flange Face	mm	103	103	115	130	190	236	235	243	310	340	360	370
	Operating Torque	Nm	175	545	650	1100	2220	3450	4300	5000	6200	7900	8700	12000
	Weight (Approx)	Kg	68	120	145	320	530	880	1400	1450	2325	3155	3520	*

* If valve operated by gear or manual handwheel

Notes:

Dimensions in these tables are for standard valves and are subject to change. For layout purposes please request a drawing.

Torques displayed are for standard materials of construction at the plug stem, check with Audco Valves if you need to carry out any actuator sizing

Weights are approximate and for bare stem valve

To maintain a compact face to face dimension, some size/pressure class combinations may contain tapped holes in flange connections. If tapped holes are not acceptable please contact Audco, we can provide a suitable solution.

TIPV - Class 1500

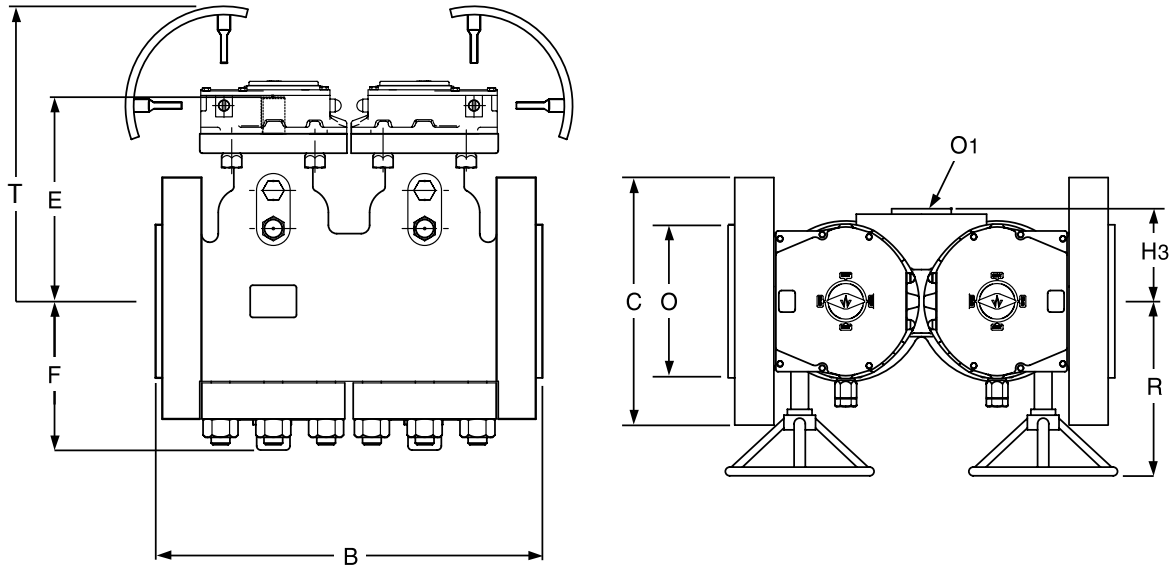

			50	80	100	150	200	250	300	350	400	450	500	600
B	Face-to-face RF	mm	369	470	546	705	832	991	1130	1257	1384	1537	1664	1943
	Face-to face RTJ	mm	372	475	549	711	841	1000	1146	1276	1407	1559	1686	1971
C	Flange Diameter	mm	216	267	312	394	483	584	673	750	826	914	984	1168
	Flange Thickness RF (incl RF ht)	mm	44.5	54	60	89	99	115	131	140	153	169	184	210
	Flange Thickness RTJ (incl RTJ ht)	mm	46	56	62	92	103	119	135	144	164	180	196	224
	Handwheel Diameter	mm	300	300	300	500	400	400	400	500	500	500	600	*
E	CL to top of Stem	mm	225	285	308	390	450	504	570	530	670	636	740	*
F	CL to bottom of Body Cap	mm	146	172	195	251	300	345	388	408	495	545	567	*
O	RF Diameter	mm	92	127	157	216	270	324	381	413	470	533	584	692
	RTJ Diameter	mm	124	168	194	248	318	372	438	489	546	613	673	794
T	CL to top of Handwheel	mm	365	424	436	610	610	845	845	775	870	860	949	*
R	CL to face of Handwheel	mm	272	299	299	445	370	465	500	484	500	529	563	*
O1	Bleed Size	mm	1/2"	1/2"	1/2"	1/2"	1"	1"	1"	1"	1"	1"	1"	1"
		CL.1500	CL.1500	CL.1500	CL.1500	CL.1500	CL.1500	CL.1500	CL.1500	CL.1500	CL.1500	CL.1500	CL.1500	CL.1500
H3	CL to end of Bleed Flange Face	mm	103	103	120	159	186	242	295	295	355	377	466	*
	Operating Torque	Nm	355	680	650	2330	2200	3850	5049	4950	6800	8900	1140	*
	Weight (Approx)	mm	68	130	195	580	722	1241	1965	2250	3188	3700	5987	*

* If valve operated by gear or manual handwheel

Notes:

Dimensions in these tables are for standard valves and are subject to change. For layout purposes please request a drawing.

Torques displayed are for standard materials of construction at the plug stem, check with Audco Valves if you need to carry out any actuator sizing

Weights are approximate and for bare stem valve

To maintain a compact face to face dimension, some size/pressure class combinations may contain tapped holes in flange connections. If tapped holes are not acceptable please contact Audco, we can provide a suitable solution.

TIPV - Class 2500

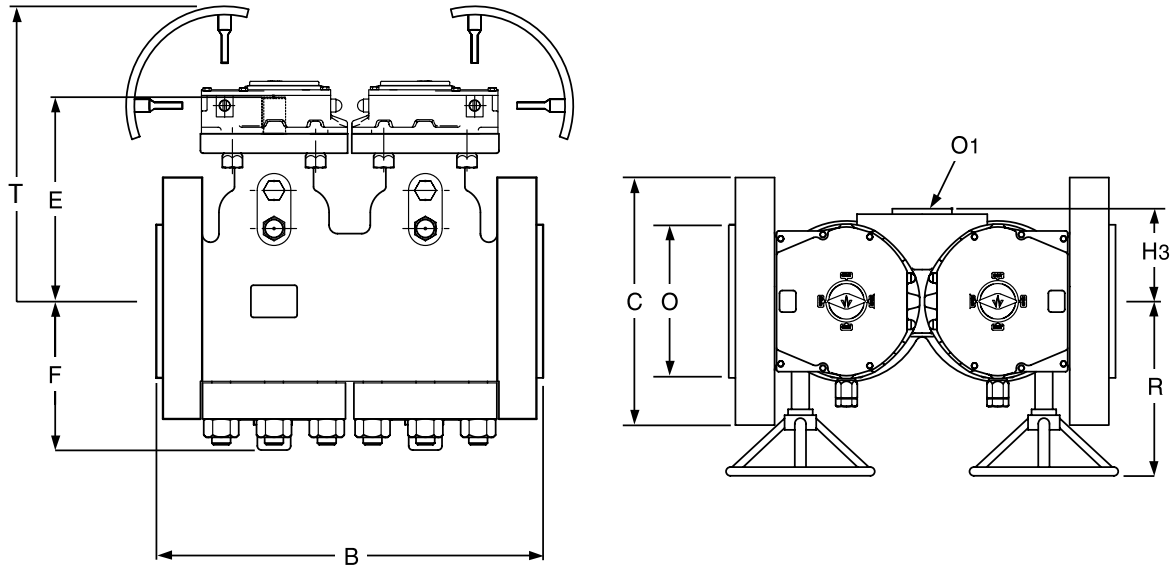

			50	80	100	150	200	250	300	350-600
B	Face-to-face RF	mm	451	578	673	914	1022	1270	1422	The dimensions for these sizes are not defined by standards and will be agreed with customer on request
	Face-to-face RTJ		454	584	683	927	1038	1292	1444	
C	Flange Diameter	mm	235	305	356	483	553	673	762	
	Flange Thickness (incl RF ht)	mm	57.2	73.0	82.6	114.4	133.4	171.5	190.0	
	Flange Thickness RF (incl RF ht)		58.7	76.2	87.3	120.6	141.2	182.6	201.0	
	Handwheel Diameter	mm	250	300	400	400	500	600	700	
E	CL to top of Stem	mm	270	335	350	404	510	545	610	
F	CL to bottom of Body Cap	mm	164	194	216	287	335	400	478	
O	RF Diameter	mm	92	127	157	216	270	324	381	
	RTJ Diameter		133	168	203	279	340	425	495	
T	CL to top of Handwheel	mm	370	450	525	566	722	802	1067	
R	CL to face of Handwheel	mm	380	4000	390	429	495	500	630	
O1	Bleed Size	mm	1/2" CL.2500	1/2" CL.2500	3/4" CL.2500	3/4" CL.2500	1" CL.2500	1" CL.2500	1" CL.2500	
H3	CL to end of Bleed Flange Face	mm	128	115	130	165	226	269	345	
	Operating Torque	Nm	730	720	1100	2620	4650	5200	6900	
	Weight (Approx)	mm	107	230	370	825	1290	2235	3380	

* If valve operated by gear or manual handwheel

Notes:

Dimensions in these tables are for standard valves and are subject to change. For layout purposes please request a drawing.

Torques displayed are for standard materials of construction at the plug stem, check with Audco Valves if you need to carry out any actuator sizing

Weights are approximate and for bare stem valve

To maintain a compact face to face dimension, some size/pressure class combinations may contain tapped holes in flange connections. If tapped holes are not acceptable please contact Audco, we can provide a suitable solution.

Sealants

Audco TIPV valves are designed in a way that no spares will be required, the only minimal maintenance can be quickly done in-line and with the valve under pressure through sealant injection. Also, in comparison to other plug valve designs, the TIPV can guarantee zero leakage seal and smooth operation with minimal sealant injection frequency.

Audco Sealants are high viscosity fluids, specially produced to seal and lubricate plug valves. Only Audco sealants should be used in Audco valves unless authorised by us. The use of a sealant or commercial greases not recommended by us can impair the functioning of the valve and in the worst case seize it completely.

Sealant is injected into the TIPV to ensure valve tight shut-off and maintain low torque. Audco sealants have excellent lubricating properties and great film strength. They supplement Super LoMu treatment to reduce friction between the seating surfaces and provide a very effective seal, even at higher line pressures.

Sealants should be selected based on service media and operating temperature. The tables below summarise our general sealant recommendations. Sealant should be carefully selected since the use of the correct Audco Sealant will minimize injection frequency. The tables are self explanatory, however, if in doubt regarding sealant selection, Audco can suggest a suitable sealant against service details.

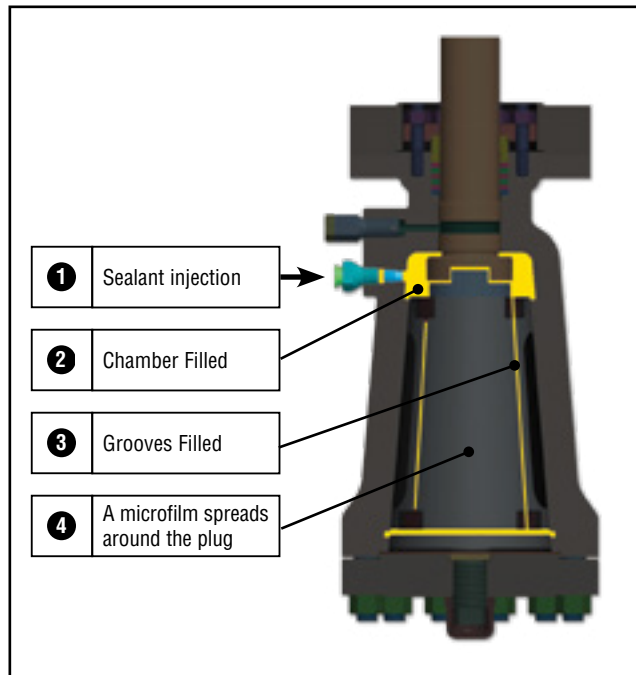

Multi-Purpose Sealants

Audco Valves research pays careful attention to the development of multi-purpose sealants to simplify plant maintenance where many services are encountered. As a result, we are able to offer three sealants which cover a very wide variety of services and have replaced many of the older Audco sealants. A single multi-purpose Audco sealant can often be used throughout an entire plant, often handling a variety of fluids. This simplifies maintenance and reduces the number of sealants which need to be kept.

Sealant	Form	Colour	Temp Range °C (°F)		Recommended for	Do not use on
			Min	Max		
733	K Sticks Cartridges Bulk	Cream	-20 (-5)	250 (480)	Most Hydrocarbon services, Butane, propane, gasoline, kerosene, oils, fuel oils, most hydrocarbon solvents. Sweet and sour natural and manufactured gas with water organic condensates, LPG systems, glycols	Strong alkali and high aromatic and chlorinated solvents
735	K Sticks Hard grade Bulk only	Black	-40 (-40)	325 (620)	Premium Multipurpose Sealant suitable for a range of fluids including hydrocarbon, water, amines and methanol Suitable for high / low temperature applications	Neat petroleum products Strong mineral acids Chlorinated and aromatic acids
731	K Sticks Cartridges Bulk	Cream	-15 (0) -20 (-5) -25 (-13)	230 (450) 230 (450) 230 (450)	Most chemical plant services, compressed air, water, aqueous solutions, dilute acids, all alkaline solutions tars and bitumens	Strong acid solutions, hydrocarbons, chlorinated and aromatic solvents

Specialised Sealants

Even though our multipurpose sealants can cover most applications, we can still supply our range of specialised sealants for those customers that prefer to use them.

Sealant	Form	Colour	Temp Range °C (°F)		Recommended for	Do not use on
			Min	Max		
985	K Sticks Cartridges Soft grade Bulk only	Light Brown	-10 (12)	150 (300)	Sweet and sour natural and manufactured gas with water/organic condensates Preferred at elevated temperatures	As 733
201	K Sticks Cartridges Bulk	White	-7 (-20)	200 (390)	Domestic water services, foodstuffs and pharmaceuticals	As 731
147	K Sticks Cartridges Bulk	White	-10 (14)	70 (160)	Nitrating acids, sulphuric acid and other oxidising elements	Hydrocarbon chlorinated and aromatic solvents
563	K Sticks Cartridges Bulk	Yellow	-10 (14)	150 (300)	Chlorinated and aromatic hydrocarbon solvents	Strong acids, nitrating acids, water and water based services and alcohols
734	K Sticks Cartridges Bulk	Cream	0 (32)	170 (340)	Water, high pressure, hot water and steam	As 731
591	K Sticks Cartridges Bulk	Cream	0 (32)	300 (570)	Petroleum based heat transfer oils. Hot fuel oil to 120°C	As 733
608	K Sticks Cartridges Bulk	Off White	0 (32)	340 (650)	Hot hydrocarbon gases and vapours including high temperature cracking and reforming Strong acids and alkalis to 150°C	Aromatic and chlorinated solvents Liquid hydrocarbons and nitrating acids
733LT	K Sticks Cartridges Bulk	Brown	-30 (-20) -46 (-50)	150 (300) 100 (200)	As for 733, but particularly useful at lower temperatures and winter conditions	As for 733
574	Cartridges Soft grade Bulk only	Beige	-50 (-58)	50 (120)	Ammonia and brine	As 731
2977	K Sticks Cartridges Soft grade Bulk only	Black	-40 (-40)	325 (620)	As for 735, also oil and water mixtures where water content is above 50% in the mixture	As 735

Sealant Injection Equipment

To ensure sealant injection is a quick and easy operation, all TIPV pressure balanced plug valves are fitted with giant button head sealant injectors positioned as a side feed in the body. All injection equipment is fitted with flexible hoses giving a hook-on connection to the sealant injectors on the valve, enabling a safe set up for the injection operation in just a few seconds.

The sealant injection equipment is specialized high pressure equipment and no other injection tools shall be used unless with our express recommendation.

400-D Sealant Gun

Hand operated hydraulic gun, fitted with a pressure gauge. Suitable for small number of valves or valves in remote locations, this gun is designed to take Size 'K' sealant sticks.

Effortless to operate, the 400D gives positive indication of when a valve has been fully charged.

The 400D replaces the now obsolete ALG4 gun. Cartridges for use with ALG4 gun are still available.



10-90 Pneumatic Pump

Trolley mounted, pneumatically operated large capacity injector pump. Suitable for large numbers or sizes of valves, the pump is designed to take five Quarter sealant cans. The pump will run when connected to an air supply that could be a compressed air system or an air bottle.

Sealants Packaging

Sealant is packed in different forms to enable its use with the different available injection equipment.

Sealants Packaging	K Sticks – Box of 12	Cartridges – Box of 12	5 Quarter Can
For Use on	400D Sealant Gun	ALG4 Gun (superseded)	10-90 Pneumatic Pump
Stick Size (mm)	35ø x 240	50ø x 220	192ø x 203
Box Size (mm)	150 x 180 x 280	165 x 205 x 245	n/a
Box Weight (Kg)	4	5.2	5

Weights will vary from those shown over a range of approximately 20-30% according to grade of sealant. Sealant can also be purchased in bulk large containers of 18Kg, 80Kg and 180 Kg

Audco Stem Packing Compound

Audco Stem Packing Compound is a special graphite based material prepared in stick form for easily sealing the stems of our TIPV valves. At any time and even with the valve under full pressure the stem packing can be re-injected to restore original stem tightness.

Stem packing is not sealant and must under no circumstances be used in the valve sealant system. Also, valve sealants are not suitable for sealing stems. Stem packing compound is supplied packed in boxes as follows:

Stick Size	A	B	D
Suitable for valves in sizes	½” – 1”	1 ½” – 2”	≥3”
Number of Sticks per Container	40	24	24
Box Size (mm)	70ø x 60	70ø x 60	70ø x 150
Box Weight (Gr)	100	100	330

The Products of Success

Super-H Pressure Balanced Plug Valve



A high pressure plug valve, achieving exceptional reliability on both leak tightness and operability. The valve ensures long-term line and atmospheric sealing, minimizes routine maintenance, and is fire tested to API6FA.

Materials: Carbon Steel, Alloy Steel, Duplex Stainless Steel and Special Materials
Sizes: 15 to 1050mm
Pressures: Up to 690 bars (10000 psi) Maximum Cold Working Pressure
Temperatures: -46°C to +325°C
Ratings: ANSI 150-2500, API 2000, 3000, 5000 and 10000

Double Isolation Plug Valve (DIPV)



DIPV gives all the advantages of our pressure balanced plug valve but also provides a double block and bleed system with true double isolation and two independent obturators in an extremely compact form.

In the DIPV, the plugs are mounted in inverse orientation to obtain the maximum port area

Materials: Carbon Steel, Alloy Steel, Duplex Stainless Steel and Special Materials
Sizes: 15 to 600mm
Pressures: Up to 690 bars (10000 psi) Maximum Cold Working Pressure
Temperatures: -46°C to +325°C
Ratings: ANSI 150-2500, API 2000, 3000, 5000 and 10000

Twin Isolation Plug Valve (TIPV)



TIPV gives all the advantages of our pressure balanced plug valve but also provides a double block and bleed system with true double isolation and two independent obturators in an extremely compact form.

In the TIPV, the plugs are mounted in same orientation to facilitate installation on particular plant layouts

Materials: Carbon Steel, Alloy Steel, Duplex Stainless Steel and Special Materials
Sizes: 15 to 600mm
Pressures: Up to 690 bars (10000 psi) Maximum Cold Working Pressure
Temperatures: -46°C to +325°C
Ratings: ANSI 150-2500, API 2000, 3000, 5000 and 10000

Full Bore Plug Valve (FBPV)



Based on the Super-H valve design, the FBPV is designed for extremely abrasive applications where valves are required to be piggable, and turbulence or obstruction to the flow path is not allowed.

Materials: Carbon Steel, Alloy Steel, Duplex Stainless Steel and Special Materials
Sizes: 15 to 600mm
Pressures: Up to 690 bars (10000 psi) Maximum Cold Working Pressure
Temperatures: -46°C to +325°C
Ratings: ANSI 150-2500, API 2000, 3000, 5000 and 10000

Steam Jacketed Plug Valve



For all applications where the media needs to be maintained at elevated temperatures and metal to metal seats are required, such as molten sulphur, the SAV steam jacketed plug valve provides the best solution. Also suitable for high pressures, it will be supplied with oversized flanges for full jacket option.

Materials: Carbon Steel and Special Materials if required
Sizes: 50x25x50 to 300x250x300mm (higher sizes upon request)
Pressures: Up to 690 bars (10000 psi) Maximum Cold Working Pressure
Temperatures: -46°C to +325°C
Ratings: ANSI 150-2500, API 2000, 3000, 5000 and 10000



Flowserve India Controls Pvt Ltd
B-8, CMDA Industrial Area,
Maraimalai Nagar - 603 209,
Kanchipuram Dist, Tamil Nadu, India.
(T) +91-44-27452323
(F) +91-44-27452327
Email : Audcoplugindia@flowserve.com

FCD AUJETB0005-01 06/13.

To find your local Flowserve representative

or for more information about Flowserve Corporation,
visit www.flowserve.com or call USA 1 800 225 6989

Flowserve Corporation has established industry leadership in the design and manufacture of its products. When properly selected, this Flowserve product is designed to perform its intended function safely during its useful life. However, the purchaser or user of Flowserve products should be aware that Flowserve products might be used in numerous applications under a wide variety of industrial service conditions. Although Flowserve can (and often does) provide general guidelines, it cannot provide specific data and warnings for all possible applications. The purchaser/user must therefore assume the ultimate responsibility for the proper sizing and selection, installation, operation, and maintenance of Flowserve products. The purchaser/user should read and understand the Installation Operation Maintenance (IOM) instructions included with the product, and train its employees and contractors in the safe use of Flowserve products in connection with the specific application.

While the information and specifications contained in this literature are believed to be accurate, they are supplied for informative purposes only and should not be considered certified or as a guarantee of satisfactory results by reliance thereon. Nothing contained herein is to be construed as a warranty or guarantee, express or implied, regarding any matter with respect to this product. Because Flowserve is continually improving and upgrading its product design, the specifications, dimensions and information contained herein are subject to change without notice. Should any question arise concerning these provisions, the purchaser/user should contact Flowserve Corporation at any one of its worldwide operations or offices.

© 2013 Flowserve Corporation, Irving, Texas, USA. Flowserve is a registered trademark of Flowserve Corporation.