

MIL 21000 / 70000 - Heavy Post Guided Single Seated Control Valves

Standard sizes & rating

½" to 10" : ASME 150# to ASME 2500#

Seat leakage class (as per FCI 70.2)

Standard : Class IV

Optional : Class V & Class VI



Applications

- For moderate pressure drops
- Handle fluids like air, water, steam, gas, oil and other fluids having wide flow range requirements
- Allowing small particles.
- In power plants for Boiler blowdown, Heater drain valves, Fuel oil control valves etc.
- In Refineries and petrochemicals for handling normal and viscous fluids

More information:

www.ksb-mil.com



Micro-flow high pressure drop plug and seat construction with extra guiding



Double stage low noise / anti-cavitation trim design for severe service



Committed to an emission free world. Bellows sealed valves for zero gland leakage

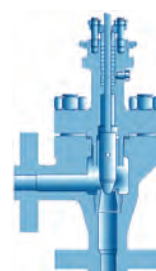

Typical MIL 70000 Angle body construction

Your contact:



MIL 21000 / 70000 - Heavy Post Guided Single Seated Control Valves

- 1 Challenging Performance Limits**
 - Precise control over wide range of flow
- 2 Design Features**
 - Heavy top guiding (shank guiding)
 - Tight shut off capability
 - Customized valve trim to meet emerging demands
- 3 Optional Characters**
 - Steam jacketing
 - Clamped seat ring
 - Extended bonnet design
- 4 Field Proven Material**
 - High Performance material for better longevity
- 5 Easy Maintenance**
 - Fewer internal trim parts
 - Quick change trim

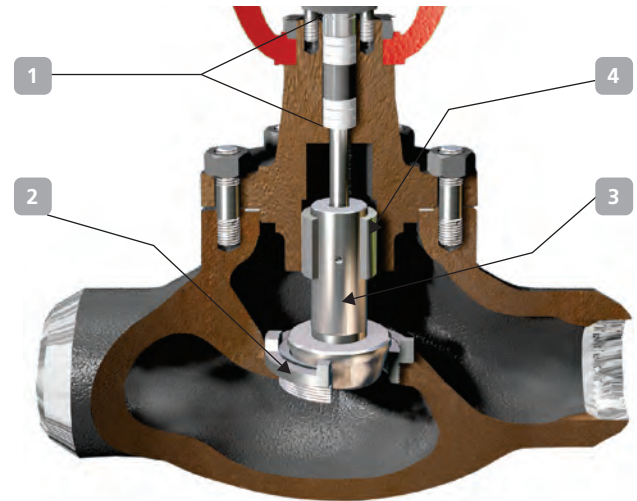

1 Packing Box 2 Seat Ring 3 Plug Stem Sub-assembly 4 Guide bush

Model Decodification

1 st	2 nd	3 rd	4 th	5 th	6 th	7 th
Actuator Type		Body Series		Plug Type	Trim Type	Seat Type
20. Hand Operated	37. Direct Spring Diaphragm	21. Top Guided Globe Control Valve	70. Top Guided Angle Control Valve	0. Undefined	0. Undefined	0. Undefined
38. Reverse Spring Diaphragm	67. Direct Piston Cylinder			1. Contoured	1. Linear	4. Clamped (Quick Change)
68. Reverse Piston Cylinder	68. Reverse Piston Cylinder			7. Single Stage Anti cavitation/Lo-dB	2. Equal %	5. Threaded
90. Electrical Actuator				8. Double Stage Anti-cavitation	3. Customised	6. Soft Seat
				9. Double Stage Lo-dB	X. On-Off	

General Data

Body	Type	High capacity Globe or Angle
	Recommended flow directions	Flow to open (except Anti-cav design) Anti-cav design : Flow to close
Bonnet	Type	Stud bolted
	Temperature range	Standard bonnet: -27° C to 427° C, Extension bonnet (AB): -100° C to 566° C, Cryogenic bonnet (CB): -196° C to -100° C
Gland Seal	Type	Adjustable double sealed packing box with PTFE or Graphite moulded split rings
	Option	Eco lock* (varying density for low emission, PTFE or Graphite) or PTFE V rings
Trim	Temperature range	≤ 180° C for PTFE, > 180° C for Graphite
	Type	Top guided (Shank guiding)
	Plug type	Contoured / Anti-cavitation / Lo-dB/ with PTFE inserts for Class VI Leakage (if Cv > 6)
	Seat type	Threaded / Clamped (Quick Change)/ Soft seat with PTFE inserts, for Class VI leakage (if Cv < 6)
	Guiding	Top guiding
	Rangeability	50:1
	Characteristic	Standard: Linear / Equal % / Quick Opening, Anti-cav / Lo-dB: Linear

* Meets the stringent Class A emission requirement as per ISO 15848



KSB MIL Controls Limited
 Meladoor, Annamanada, Pin - 680741
 Thrissur District, Kerala, India
 Tel. +91 480 2695700, Fax. +91 480 2890952
 E-mail: sales.mil@ksb.com, www.ksb-mil.com

You can also visit us at:
www.ksb.com/socialmedia