



Type GLC

Globe Valve
Cast Steel, Pressure seal Bonnet
Butt weld ends

2" - 8" (50-200 mm)
Class 900, 1500, 2500

Design in accordance with ASME B16.34

Applications

- Power stations, general industry, process engineering
- For water, steam, gas, oil & other non-aggressive media
- Further applications on request

Operating Data

- Pressure up to 431 bar (6250 psi)
- Temperature up to +650°C / 1200°F
- Minimum temperature is 0°C (less than 0°C on request)
- Pressure-temperature ratings as per ASME B 16.34, Standard class

Materials

- ASTM A 216 WCB from 0°C to 425°C
- ASTM A 217 WC6/WC9 from 0°C to 593°C
- ASTM A 217 C12A from 0°C to 650°C

Design

- As per ASME B 16.34
- Pressure Seal Bonnet Design
- Stellite hard-faced Seats & Disc surface
- Graphite gaskets & packings with Braided wiping rings
- Direct retrofitting of Actuator
- The Valves meet the safety requirement of the Pressure Equipment Directive 97/23/EC(PED) of annex I for fluids of the groups 1 and 2.

Variants on Request

- Bypass Arrangement
- Gear / Electrical Actuator
- Position indicator
- Locking Arrangement
- Stem Protector
- Special class execution
- Other Material of construction

Remarks :

(Type Series Booklet References)

SICCA 800-2500 GTF / GLF / PCF	: 7240.1/01-14
SICCA 900-2500 GTC	: 7241.2/01-14
SICCA 900-2500 SCC	: 7243.2/01-14
SICCA 150-600 GTC	: 7244.2/01-14
SICCA 150-600 GLC	: 7245.2/01-14
SICCA 150-600 SCC	: 7246.2/01-14
Operating instructions no.	: 0500.80/06-18 G3

On all enquiries / orders please specify :

1. Type
2. ASME Pressure class
3. Size
4. Design pressure/temperature
5. Operating pressure
6. Operating temperature
7. Differential pressure
8. Material of construction
9. Flow medium
10. Flow rate Min./Max.
11. Type of end connection
12. Pipe Schedule Inlet/ Outlet Dia
13. Variants
14. Type Series Booklet no.
15. Valve data sheet (if applicable)

When ordering spares, Indicate Serial number of Valve.

Product features to our customer benefit

Stem nut with thrust bearing enables retrofitting of actuators at site.

Burnished & smooth finished stem

Graphite packing ring with top & bottom rings of braided graphite

Knock out hole

Graphite gasket

Bonnet

Body

Seal welded Seat ring ST6 (HF)

Body

2" to 6"

- Valves meets ASME 16.34 requirements
- Compact yoke design ensures low valve weight
- Designed to retrofit valve with Actuator at site without disassembly of pressure retaining parts
- Stem lock arrangement ensures non-rotation of stem
- 'Y' Pattern body minimizes pressure drop

Body Guided Disc

Disc Seat ST6 (HF)

Body Seat ST6 (HF)

Flow Seal

- Fully stellite body seat & disc seat
- Seat rings - Seal welded to body
- Valves will be with flow over disc to ensure leak tightness under high / full differential pressures.

Disc Design

- Disc - Body guided, which stands unbalanced forces at high differential pressure
- Stellite-6 hard faced seating surface enhances sealing life

Stem Disc Connection

- Stem-disc joint capable of withstanding vibration during valve opening

Self aligning gland

Gland bush

Braided Graphite wiping rings at top & bottom

Die moulded Graphite rings

Stem

Integral Stellite-6 (HF) Backseat

Gland Seal

- Die moulded graphite rings ensures effective sealing to atmosphere
- Top & bottom rings are braided graphite and inconel reinforced
- Braided rings offer smooth wiping action thereby arresting graphite depletion
- Smooth finished & polished stem and smooth stuffing box surfaces improve gland sealing life
- Two piece self aligning gland arrangement
- Integral hard faced back seat for maximum service life

Thrust ring

Spacer ring

Graphite gasket

Body

Bonnet

Pressure Seal Bonnet

- Die moulded graphite gasket
- Segmental ring arrangement with knock-out hole ensures easy disassembly

Retrofitting of Actuator & By-pass Execution

Key

Nut

Stem

By-pass Valve

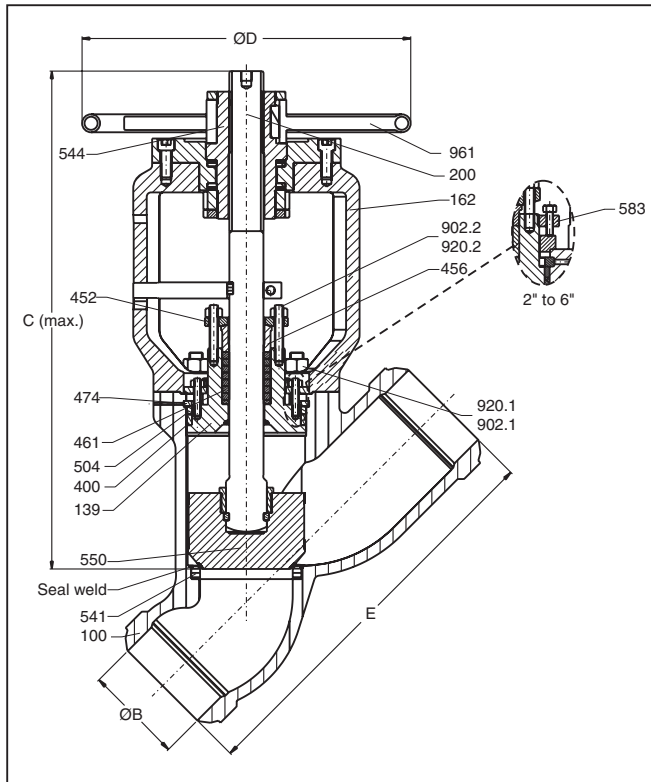

Design Specifications

General valve design & pressure, temperature rating : ASME B 16.34
 Butt weld end design : ASME B 16.25
 End to end dimension : ASME B 16.10
 Testing : API 598

Dimensions in mm

Class 900

Size (Inch)	2"	3"	4"	6"	8"
E	368	381	457	610	737
ØB*	49.5	73.5	92	139.5	182.5
C (max)	488	597	666	925	1091
ØD	254	457	610	610	577

* Schedule 80 up to 3". Schedule 120 for 4" and above.
 Alternate schedule on request.

Class 1500

Size (Inch)	2"	3"	4"	6"
E	368	470	546	705
ØB*	43	66.5	87.5	131.5
C (max)	562	628	752	1022
ØD	457	610	610	610

* Schedule 160. Alternate schedule on request.

Class 2500

Size (Inch)	2"	3"	4"	6"
E	451	578	673	914
ØB*	38	58.5	80	124.5
C (max)	556	675	761	1038
ØD	457	610	610	610

* Schedule XXS. Alternate schedule on request.

Materials

Part No.	Description	Material			
		A 216-WCB	A 217-WC6	A 217-WC9	A 217-C12A
100	Body	A 216-WCB	A 217-WC6	A 217-WC9	A 217-C12A
139	Bonnet ¹⁾	A 216-WCB+ST6 / A 105+ST6	A 217-WC6+ST6 / A 182-F11+ST6	A 217-WC9+ST6 / A 182-F22+ST6	A 217-C12A+ST6 / A 182-F91+ST6
162	Yoke	A 216-WCB	A 217-WCB	A 216-WCB	A 217-WC9
200	Stem	A 479-410-2	A 479-410-2	A 479-410-2	A 479-XM19-A
324	Thrust bearing	FAG/EQUIVALENT	FAG/EQUIVALENT	FAG/EQUIVALENT	FAG/EQUIVALENT
400	Gasket	GRAPHITE	GRAPHITE	GRAPHITE	GRAPHITE
452	Gland flange	IS 2002-2	IS 2002-2	IS 2002-2	A 182-F22 CL3
456	Gland bush	A 276-410	A 276-410	A 276-410	A 182-F22
457	Packing ring	A 439-D2	A 439-D2	A 439-D2	A 439-D2
461	Gland packing	GRAPHITE	GRAPHITE	GRAPHITE	GRAPHITE
474	Thrust ring	A 336-F91	A 336-F91	A 336-F91	A 336-F91
504	Spacer ring	A 182-F22 CL3	A 182-F22 CL3	A 182-F22 CL3	A 182-F22 CL3
541	Seat ring	A 105+ST6	A 182-F22+ST6	A 182-F22+ST6	A 182-F91+ST6
544	Stem nut	AL. BRONZE	AL. BRONZE	AL. BRONZE	AL. BRONZE
550	Disc ²⁾	A 216-WCB+ST6 / A 105+ST6	A 217-WC9+ST6 / A 182-F22+ST6	A 217-WC9+ST6 / A 182-F22+ST6	A 217-C12A+ST6 / A 182-F91+ST6
583.1	Bonnet retainer	IS 2002-2 (A 516-60)	A 182-F22 CL3	A 182-F22 CL3	A 182-F22 CL3
583.2	Retaining plate	IS 2002-2 (A 516-60)	A 182-F22 CL3	A 182-F22 CL3	A 182-F22 CL3
701.1	By-pass tube	A 106-B	A 335-P22	A 335-P22	A 335-P91
741.1	By-pass valve	A 105	A 182-F22	A 182-F22	A 182-F91
901	Hex. bolt	A 193-B7	A 193-B7	A 193-B7	A 193-B7
902.1 / .2	Stud	A 193-B7	A 193-B16	A 193-B16	A 193-B16
920.1 / .2	Hex. nut	A 194-2H	A 194-4/7	A 194-4/7	A 194-4/7
961	Handwheel	SG IRON / Carbon Steel	SG IRON / Carbon Steel	SG IRON / Carbon Steel	SG IRON / Carbon Steel

1) Casting only for 6" #900, 8" #900, 6" #1500, 4" #2500, 6" #2500

2) Casting only for 6" #1500, 6" #2500, 8" #900

Testing

Test / Test pressure	#900		#1500		#2500		Testing medium
	kg/cm ²	psi	kg/cm ²	psi	kg/cm ²	psi	
Shell	238	3375	396	5625	660	9375	Water
Seat	175	2475	291	4125	484	6875	
Back Seat	175	2475	291	4125	484	6875	

Pressure Temperature Rating - Standard Class
Rating for Group 1.1 Material : A 216 Gr. WCB ⁽¹⁾

Temperature		# 900		# 1500		# 2500	
°F	°C	PSI	Kg/cm ²	PSI	Kg/cm ²	PSI	Kg/cm ²
-20 to 100	-29 to 38	2220.0	156.1	3705.0	260.5	6170.0	433.8
200	93.3	2035.0	143.1	3395.0	238.7	5655.0	397.6
300	148.9	1965.0	138.2	3270.0	229.9	5450.0	383.2
400	204.4	1900.0	133.6	3170.0	222.9	5280.0	371.2
500	260.0	1810.0	127.3	3015.0	212.0	5025.0	353.3
600	315.6	1705.0	119.9	2840.0	199.7	4730.0	332.6
650	343.3	1650.0	116.0	2745.0	193.0	4575.0	321.7
700	371.1	1590.0	111.8	2665.0	187.4	4425.0	311.1
750	398.9	1520.0	106.9	2535.0	178.2	4230.0	297.4
800	426.7	1235.0	86.8	2055.0	144.5	3430.0	241.2
850	454.4	955.0	67.1	1595.0	112.1	2655.0	186.7
900	482.2	690.0	48.5	1150.0	80.9	1915.0	134.6
950	510.0	410.0	28.8	685.0	48.2	1145.0	80.5
1000	537.8	255.0	17.9	430.0	30.2	715.0	50.3

1) Permissible, but not recommended for prolonged use above 800°F

1 Kg/cm² = 0.981 Bar

Rating for Group 1.9 Material : A 217 Gr. WC6 ⁽¹⁾⁽²⁾

Temperature		# 900		# 1500		# 2500	
°F	°C	PSI	Kg/cm ²	PSI	Kg/cm ²	PSI	Kg/cm ²
-20 to 100	-29 to 38	2250.0	158.2	3750.0	263.7	6250.0	439.4
200	93.3	2250.0	158.2	3750.0	263.7	6250.0	439.4
300	148.9	2165.0	152.2	3610.0	253.8	6015.0	422.9
400	204.4	2080.0	146.2	3465.0	243.6	5775.0	406.0
500	260.0	1995.0	140.3	3325.0	233.8	5540.0	389.5
600	315.6	1815.0	127.6	3025.0	212.7	5040.0	354.3
650	343.3	1765.0	124.1	2940.0	206.7	4905.0	344.9
700	371.1	1705.0	119.9	2840.0	199.7	4730.0	332.6
750	398.9	1595.0	112.1	2660.0	187.0	4430.0	311.5
800	426.7	1525.0	107.2	2540.0	178.6	4230.0	297.4
850	454.4	1460.0	102.6	2435.0	171.2	4060.0	285.4
900	482.2	1350.0	94.9	2245.0	157.8	3745.0	263.3
950	510.0	955.0	67.1	1595.0	112.1	2655.0	186.7
1000	537.8	650.0	45.7	1080.0	75.9	1800.0	126.6
1050	565.6	430.0	30.2	720.0	50.6	1200.0	84.4
1100	593.3	290.0	20.4	480.0	33.7	800.0	56.2
1150	621.1	195.0	13.7	325.0	22.8	545.0	38.3
1200	648.9	125.0	8.8	205.0	14.4	345.0	24.3

1) Use Normalised and tempered material only.

2) Not to be used over 1100°F

Rating for Group 1.10 Material : A 217 Gr. WC9 ⁽¹⁾⁽²⁾

Temperature		# 900		# 1500		# 2500	
°F	°C	PSI	Kg/cm ²	PSI	Kg/cm ²	PSI	Kg/cm ²
-20 to 100	-29 to 38	2250.0	158.2	3750.0	263.7	6250.0	439.4
200	93.3	2250.0	158.2	3750.0	263.7	6250.0	439.4
300	148.9	2185.0	153.6	3640.0	255.9	6070.0	426.8
400	204.4	2115.0	148.7	3530.0	248.2	5880.0	413.4
500	260.0	1995.0	140.3	3325.0	233.8	5540.0	389.5
600	315.6	1815.0	127.6	3025.0	212.7	5040.0	354.3
650	343.3	1765.0	124.1	2940.0	206.7	4905.0	344.9
700	371.1	1705.0	119.9	2840.0	199.7	4730.0	332.6
750	398.9	1595.0	112.1	2660.0	187.0	4430.0	311.5
800	426.7	1525.0	107.2	2540.0	178.6	4230.0	297.4
850	454.4	1460.0	102.6	2435.0	171.2	4060.0	285.4
900	482.2	1350.0	94.9	2245.0	157.8	3745.0	263.3
950	510.0	1160.0	81.6	1930.0	135.7	3220.0	226.4
1000	537.8	800.0	56.2	1335.0	93.9	2230.0	156.8
1050	565.6	525.0	36.9	875.0	61.5	1454.0	102.2
1100	593.3	330.0	23.2	550.0	38.7	915.0	64.3
1150	621.1	205.0	14.4	345.0	24.3	570.0	40.1
1200	648.9	125.0	8.8	205.0	14.4	345.0	24.3

1) Use Normalised and tempered material only.

2) Not to be used over 1100°F

Rating for Group 1.15 Material : A 217 Gr. C12A

Temperature		# 900		# 1500		# 2500	
°F	°C	PSI	Kg/cm ²	PSI	Kg/cm ²	PSI	Kg/cm ²
-20 to 100	-29 to 38	2250.0	158.2	3750.0	263.7	6250.0	439.4
200	93.3	2250.0	158.2	3750.0	263.7	6250.0	439.4
300	148.9	2185.0	153.6	3640.0	255.9	6070.0	426.8
400	204.4	2115.0	148.7	3530.0	248.2	5880.0	413.4
500	260.0	1995.0	140.3	3325.0	233.8	5540.0	389.5
600	315.6	1815.0	127.6	3025.0	212.7	5040.0	354.3
650	343.3	1765.0	124.1	2940.0	206.7	4905.0	344.9
700	371.1	1705.0	119.9	2840.0	199.7	4730.0	332.6
750	398.9	1595.0	112.1	2660.0	187.0	4430.0	311.5
800	426.7	1525.0	107.2	2540.0	178.6	4230.0	297.4
850	454.4	1460.0	102.6	2435.0	171.2	4060.0	285.4
900	482.2	1350.0	94.9	2245.0	157.8	3745.0	263.3
950	510.0	1160.0	81.6	1930.0	135.7	3220.0	226.4
1000	537.8	1090.0	76.6	1820.0	128.0	3030.0	213.0
1050	565.6	1080.0	75.9	1800.0	126.6	3000.0	210.9
1100	593.3	905.0	63.6	1510.0	106.2	2515.0	176.8
1150	621.1	670.0	47.1	1115.0	78.4	1855.0	130.4
1200	648.9	430.0	30.2	720.0	50.6	1200.0	84.4

Pressure Temperature Rating - Special Class

Rating for Group 1.1 Material : A 216 Gr. WCB ⁽¹⁾

Temperature		# 900		# 1500		# 2500	
°F	°C	PSI	Kg/cm ²	PSI	Kg/cm ²	PSI	Kg/cm ²
-20 to 100	-29 to 38	2250.0	158.2	3750.0	263.7	6250.0	439.4
200	93.3	2250.0	158.2	3750.0	263.7	6250.0	439.4
300	148.9	2220.0	156.1	3700.0	260.1	6170.0	439.4
400	204.4	2200.0	154.7	3665.0	257.7	6105.0	429.2
500	260.0	2200.0	154.7	3665.0	257.7	6105.0	429.2
600	315.6	2200.0	154.7	3665.0	257.7	6105.0	429.2
650	343.3	2145.0	150.8	3575.0	251.3	5960.0	419.0
700	371.1	2075.0	145.9	3455.0	242.9	5760.0	405.0
750	398.9	1905.0	133.9	3170.0	222.9	5285.0	371.6
800	426.7	1545.0	108.6	2570.0	180.7	4285.0	301.3
850	454.4	1195.0	84.0	1995.0	140.3	3320.0	233.4
900	482.2	860.0	60.5	1435.0	100.9	2395.0	168.4
950	510.0	515.0	36.2	855.0	60.1	1430.0	100.5
1000	537.8	320.0	22.5	535.0	37.6	895.0	62.9

1) Permissible, but not recommended for prolonged use above 800°F

1 Kg/cm² = 0.981 Bar

Rating for Group 1.9 Material : A 217 Gr. WC6 ⁽¹⁾⁽²⁾

Temperature		# 900		# 1500		# 2500	
°F	°C	PSI	Kg/cm ²	PSI	Kg/cm ²	PSI	Kg/cm ²
-20 to 100	-29 to 38	2250.0	158.2	3750.0	263.7	6250.0	439.4
200	93.3	2250.0	158.2	3750.0	263.7	6250.0	439.4
300	148.9	2250.0	158.2	3750.0	263.7	6250.0	439.4
400	204.4	2250.0	158.2	3750.0	263.7	6250.0	439.4
500	260.0	2250.0	158.2	3750.0	263.7	6250.0	439.4
600	315.6	2250.0	158.2	3750.0	263.7	6250.0	439.4
650	343.3	2250.0	158.2	3750.0	263.7	6250.0	439.4
700	371.1	2200.0	154.7	3665.0	257.7	6110.0	429.6
750	398.9	2185.0	153.6	3645.0	256.3	6070.0	426.8
800	426.7	2160.0	151.9	3600.0	253.1	6000.0	421.8
850	454.4	2030.0	142.7	3385.0	238.0	5645.0	396.9
900	482.2	1760.0	123.7	2935.0	206.4	4895.0	344.2
950	510.0	1195.0	84.0	1995.0	140.3	3320.0	233.4
1000	537.8	810.0	56.9	1350.0	94.9	2250.0	158.2
1050	565.6	540.0	38.0	900.0	63.3	1500.0	105.5
1100	593.3	360.0	25.3	600.0	42.2	1000.0	70.3
1150	621.1	245.0	17.2	405.0	28.5	680.0	47.8
1200	648.9	155.0	10.9	255.0	17.9	430.0	30.2

1) Use Normalised and tempered material only.

2) Not to be used over 1100°F

Rating for Group 1.10 Material : A 217 Gr. WC9 ⁽¹⁾⁽²⁾

Temperature		# 900		# 1500		# 2500	
°F	°C	PSI	Kg/cm ²	PSI	Kg/cm ²	PSI	Kg/cm ²
-20 to 100	-29 to 38	2250.0	158.2	3750.0	263.7	6250.0	439.4
200	93.3	2250.0	158.2	3750.0	263.7	6250.0	439.4
300	148.9	2220.0	156.1	3695.0	259.8	6160.0	433.1
400	204.4	2185.0	153.6	3640.0	255.9	6065.0	426.4
500	260.0	2175.0	152.9	3620.0	254.5	6035.0	424.3
600	315.6	2165.0	152.2	3605.0	253.5	6010.0	422.5
650	343.3	2145.0	150.8	3580.0	251.7	5965.0	419.4
700	371.1	2120.0	149.1	3535.0	248.5	5895.0	414.5
750	398.9	2120.0	149.1	3535.0	248.5	5895.0	414.5
800	426.7	2120.0	149.1	3535.0	248.5	5895.0	414.5
850	454.4	2030.0	142.7	3385.0	238.0	5645.0	396.9
900	482.2	1800.0	126.6	3000.0	210.9	5000.0	351.5
950	510.0	1415.0	99.5	2360.0	165.9	3930.0	276.3
1000	537.8	1005.0	70.7	1670.0	117.4	2785.0	195.8
1050	565.6	655.0	46.1	1095.0	77.0	1820.0	128.0
1100	593.3	410.0	28.8	685.0	48.2	1145.0	80.5
1150	621.1	255.0	17.9	430.0	30.2	715.0	50.3
1200	648.9	155.0	10.9	255.0	17.9	430.0	30.2

1) Use Normalised and tempered material only.

2) Not to be used over 1100°F

Rating for Group 1.15 Material : A 217 Gr. C12A

Temperature		# 900		# 1500		# 2500	
°F	°C	PSI	Kg/cm ²	PSI	Kg/cm ²	PSI	Kg/cm ²
-20 to 100	-29 to 38	2250.0	158.2	3750.0	263.7	6250.0	439.4
200	93.3	2250.0	158.2	3750.0	263.7	6250.0	439.4
300	148.9	2250.0	158.2	3750.0	263.7	6250.0	439.4
400	204.4	2250.0	158.2	3750.0	263.7	6250.0	439.4
500	260.0	2250.0	158.2	3750.0	263.7	6250.0	439.4
600	315.6	2250.0	158.2	3750.0	263.7	6250.0	439.4
650	343.3	2250.0	158.2	3750.0	263.7	6250.0	439.4
700	371.1	2200.0	154.7	3665.0	257.7	6110.0	429.6
750	398.9	2185.0	153.6	3645.0	256.3	6070.0	426.8
800	426.7	2160.0	151.9	3600.0	253.1	6000.0	421.8
850	454.4	2030.0	142.7	3385.0	238.0	5645.0	396.9
900	482.2	1800.0	126.6	3000.0	210.9	5000.0	351.5
950	510.0	1415.0	99.5	2360.0	165.9	3930.0	276.3
1000	537.8	1260.0	88.6	2105.0	148.0	3505.0	246.4
1050	565.6	1260.0	88.6	2105.0	148.0	3505.0	246.4
1100	593.3	1130.0	79.4	1885.0	132.5	3145.0	221.1
1150	621.1	835.0	58.7	1395.0	98.1	2320.0	163.1
1200	648.9	540.0	38.0	900.0	63.3	1500.0	105.5

KSB Pumps and Valves - We are where you are

Manufacturing Plants :

Head Office & Pimpri :

Irrigation & Process Division

Mumbai-Pune Road, Pimpri,
Pune - 411 018.

Tel.: 020-2710 1000 Fax : 020-2742 6000

Chinchwad :

Power Projects Division

D-II Block, MIDC Chinchwad,
Pune - 411 019.

Tel.: 020-2740 9100 Fax : 020-2747 0890

Coimbatore :

Valves Division

151, Mettupalayam Road,
NSN Palayam Post,
Coimbatore - 641 031.

Tel.: 0422-246 8222, 246 8547-9

Fax : 0422-246 8232

Sinnar :

Water Pumps Division

Plot No. E-3 & E-4, MIDC Sinnar,
Nashik - 422 113.

Tel.: 02551-230252 / 53 / 55

Fax : 02551-230254

Vambori :

Foundry Division

Vambori, Ahmednagar - 413 704.

Tel.: 02426-272534, 272528, 272074

Fax : 02426-272043

Regd. Office :

126, Maker Chambers III, Nariman Point,
Mumbai - 400 021.

Tel.: 022-6658 8787 Fax : 022-6658 8788

Zonal Offices :

East :

30, Circus Avenue, 2nd Floor,
Kolkata - 700 017.

Tel.: 033-2287 0473, 2290 0117

Fax : 033-2287 0588

West :

126, Maker Chambers III, Nariman Point,
Mumbai - 400 021.

Tel.: 022-6658 8787 Fax : 022-6658 8788

North :

KSB House, A-96, Sector IV, NOIDA,
Dist. Gautam Budh Nagar - 201 301.

Tel.: 0120-254 1091-93, 254 1501-3

Fax : 0120-255 0567

South :

Guindy House, II Floor, 95, Anna Salai,
Chennai - 600 032.

Tel.: 044-2235 2571-2, 2235 5673

Fax : 044-2235 2749

Service Stations :

Chennai :

No. 4, (Old No. 18), Chakrapani Road,
Guindy, Chennai - 600 032.

Tel.: 044-2255 0704

Raipur :

Ring Road - 2, Behind Jeet Cold Storage,
Gondwara Road, Raipur - 493 221.

Tel.: 0771-650 1375

NOIDA :

KSB House, A-96, Sector IV, NOIDA,
Dist. Gautam Budh Nagar - 201 301.

Tel.: 0120-254 1091-92, 254 1501-2

Fax : 0120-255 0567

Odhav :

Shed No. 22, Gujrat Vepari

Mahamandal, Odhav,

Ahmedabad - 382 410.

Tel.: 079-2290 0372

Branch Offices :

Ahmedabad :

205, Simandhar Avenue, 2nd Floor,

8, Kailash Society, Opp. Nature View

Building, Near H. K. House, Ashram Rd.,

Ahmedabad - 380 009.

Tel.: 079-2657 9610 / 11

Fax : 079-2657 9612

Aurangabad :

Plot No. P 204, Shivshankar Colony,

Near Bembde Hospital,

Aurangabad - 431 005.

Tel.: 0240-235 1440, 234 2447

Fax : 0240-235 1440

Bangalore :

191, 1st Floor, West of Chord Road,

2nd Stage, Bangalore 560 086.

Tel.: 080-2349 1806, 2349 3925

Fax : 080-2349 6036

Baroda :

4-B, Ramkrishna Chamber,

Productivity Road, Baroda - 390 005.

Tel.: 0265-233 0532, 233 3226

Fax : 0265-235 0002

Bhubaneswar :

N5/39, 1st Floor, IRC Village, Nayapalli,

Bhubaneswar - 751 013.

Tel.: 0674-255 8497, 255 3061

Fax : 0674-255 8499

Chandigarh :

SCO - 189, 2nd Floor, Sector - 7C,

Chandigarh - 160 019.

Tel.: 0172-2790062, 2790072

Fax : 0172-2790062

Indore :

B-14, Ratlam Kothi, Indore - 452 001.

Tel.: 0731-252 9478, 252 9704

Fax : 0731-252 9704

Jaipur :

Anjali Chambers, 2nd Floor, Block C,

10, Rajbhawan Road, Civil Lines,

Jaipur - 302 001.

Tel.: 0141-222 4554, 222 4904

Fax : 0141-222 4904

Jamshedpur :

UG-4, Gangotri House, 'Q' Road,

Bistupur, Jamshedpur - 831 001.

Tel.: 0657-231 7129, 231 7130

Fax : 0657-231 7128

Lucknow :

309, Chintels House, 16, Station Road,

Lucknow - 226 001.

Tel.: 0522-263 5203, 263 5597

Fax : 0522-263 5597

Mumbai :

126, Maker Chambers III, Nariman Point,

Mumbai - 400 021.

Tel.: 022-6658 8787 Fax : 022-6658 8788

Nagpur :

203, Suryakiran Complex, Bajaj Nagar,

Nagpur - 440 010.

Tel.: 0712-223 6889, 222 9148

Fax : 0712-224 4184 (P.P.)

Pune :

Aamod Apartments, 'B' Wing,

Block No. 33, Behind Hotel Shravan,

Opp. Police Ground

Off Fergusson College Road,

Pune - 411 016.

Tel.: 020-25650393, 0394, 0396, 0398

Raipur :

D - 62, Sector - 2, Devendra Nagar,

Raipur - 492 001. (Chhattisgarh)

Tel.: 0771 - 2583658, 2583921

Fax : 0771 - 2583921

Secunderabad :

D. No. 12-13-197, 198,

Flat No. 103 & 104, 1st Floor,

Pavani Anusuya Towers, Tarnaka,

Secunderabad - 500 017.

Tel.: 040-2700 1724, 2700 3696

Fax : 040-2700 1725



KSB Pumps Limited

151, Mettupalayam Road, NSN Palayam Post, Coimbatore - 641 031. (India)
Tel. : +91 422 2468222 Fax : +91 422 2468232 www.ksbindia.co.in